

## Efficient Monitoring system of Plant Watering Based on Internet of Things (IoT) Using MATLAB

Muslim Majeed Hameed\*

Archiving Unit Department/ College of Fine Arts-University of Basra-Basra-Iraq

\*Corresponding author E-mail: [Muslim07801102248@gmail.com](mailto:Muslim07801102248@gmail.com)

<https://doi.org/10.29072/basjs.20240206>

<b>ARTICLE INFO</b>	<b>ABSTRACT</b>
<p><b>Keywords</b></p> <p>IoT, MATLAB, Monitoring system, Plants watering</p>	<p>This study discusses the development of embedded systems for plant monitoring and irrigation systems utilizing Internet of Things (IoT) within MATLAB environments. The IoT paradigm is designed to connect devices via the Internet and facilitate user access to data. This model can accurately observe environmental data in agricultural areas and subsequently provide comparable data to the user. The model monitors various characteristics, including temperature, humidity, and light intensity. The infrared sensors are employed to detect the entry of external objects into the fields; in the event of an intruder detection, buzzers will activate for a few seconds. The motor operates in both manual and automatic modes, contingent upon moisture sensors. The motor is regularly alternated between the ON and OFF phases of pump operations. The outcome is observed in web applications and monitoring systems. The water plant processing is often conducted manually, based on the desired water quantities for the plant. Our study discusses automatic prototypes and systems designed for plant irrigation based on moisture levels. This study offers a more secure application with greater user accessibility compared to existing solutions.</p>

Received 10 July 2024; Received in revised form 30 July 2024; Accepted 17 Aug 2024, Published 31 Aug 2024



## 1. Introduction

The increased of the Internet of Things (IoT) has completely changed the way technology and connectivity work representing steps, in combining physical devices with the digital world. The change has influenced industry offer opportunity, for innovations, efficiency and advancement. As technology continues to evolve it has reshaped business tactics and operational methods prompting companies to embrace approaches to completely leverage its potential [1]. Smart farming is an agricultural developments mode that use modern science and technology to improved agricultural productions effectiveness and decrease resources waste. With the development of the global populations and the impacts of climate change, traditional agricultures are facing numerous challenges such as lands scarcity, water scarcity, and environmental pollutions. Under this background, smart agriculture emerged as the time involve. It achieves precise management and intelligent decision-making in agricultures by apply advance sensing technology, clouds computing and IoTs [2]. Plants agriculture is one of the utmost important. plant provide control environmental condition that allow plant to grow at any times of the day or nights. At presents, the applications of IoT in agricultural plant management have become a hotspot of human attention. It has change conventional agricultures which is limited by numerous factors such as natural environment, geographical locations, and climate. Smart plant watering control systems can realize the improvement and applications of smart agriculture [3]. The plant require necessary waters of grown healthy and waters plant were work which need for doing through farmer and plants lover to care of plant. Waters plant within appropriate waters volumes are vital due to it has directs impacts on plant. Absence of waters or unnecessary waters contents could made plant drying or bad [4]. The processing of watering plant could be manual or under device mechanically. This paper is associated to the designing of a prototypes devices and plants watering systems that function routinely. The prototypes of the devices make emphasize the measurements of moisture contents to controlling the waters flows into processing of waters plant. The perseverance of paper is spraying systems can controlled a waters contents required via plant be contingent on soils moistures. Within numerous relate works was discuss nearly automatic waters devices. The author [5], they discuss the applying fuzzy logics with used of microcontroller, LM35s temperatures sensor, with soils moistures sensor exactly for celery plant. In [6], they use Atmega8535 microcontrollers and LM35 temperatures sensors which are apply to watering plant in overall. A study in [7], relate with an automatic sprinklers prototype on plant by use RTCs timer base on the



Atmega16 microcontrollers. In research [8], they discussed about the sprinklers watering systems which trigger by the temperatures and lights intensities values by use LM35 sensors, LDRs, and Atmega8535 that apply on swallow nest farms. The proposal by [9] controlled the system of water towers by use microcontrollers, sensors and SMSs, to detects the obtainability of waters in a waters tank. In [10], they discuss about the designing of plants sprinkler by use Arduino Uno, YL-39 and YL-69 sensors, relays, waters pumping and Bluetooth connections to an invent Android applications install on users' smartphones that show the values of the soils moistures. These studying was focus for controlling functions of waters device nonetheless without function that connects to IoTs platforms. Researches for IoTs are developed with implement by numerous aspect. In some instance, uses of IoTs in aspects of homes securities systems is implement by use Wemo boards microcontrollers with PIRs sensors for motions detections [11-15]. In the fields of monitors systems, the IoTs platforms has been use to records information from MQ135 air qualities sensor, process by the systems and provided notification via user smartphones when pollutions from harmful gas is detects [16]. Additional uses of IoTs illuminate in researches about the gas detectors prototypes by use MQ2 sensors and Wemos boards microcontrollers with notifications and monitoring feature. In [17-19], they discuss the uses of IoTs for irrigations by use regressions algorithms that aim to optimized and controlling of waters consumptions. In [20], they introduced a design of intelligent monitoring systems for agriculture environment by use IoT techniques. The implementation of smart plants monitors systems integrate with clouds-base servers and mobiles devices base Android/iOS which helps users to monitoring the plants status of moistures, temperatures, and lights conditions to performs the appropriate irrigations and illuminations for the plant. From numerous studies that have been reviewed before, every paper has several features to matched the need the researches itself. The foremost concern of this work round automated waters systems is for designing with implementing a waters device which controlled the spraying processing rendering to soils moistures required by the plant. For these purposes, we focus on two key concerns relate to the constructions of hardware and integrate the systems with IoTs platform. Additionally, to the prototype's devices, this paper utilizes the feature obtainable from IoTs platform. The software and hardware use to made automatically watering systems consists of a soils moistures sensors, microcontrollers, relays, solenoid valves, watering pipes, IDEs, Blynk application, and IoT. Currently, the digital worlds several farmers are still use tradition method in their fields so; yields of plant are very less. Apply a novel technique in fields will resolve foremost



issue in agricultures. The IoTs concepts are appropriate to wholly field like automations, industries, electric, electronic, health caring, track system. When plant growths automations are required to monitoring a numerous environment condition, the suggested systems is bases on monitor and watering systems for agricultures fields base on IoT which helps the farmer to applying newer approaches, could increases their incomes with lesser manual works. Conventional agricultures are changed to new agricultures. Automatically systematic techniques could apply to all kind of agriculture’s fields. IoT is connections of physical thing to operated device with helps of Internet. IoTs is the networks connections of numerous electronic things. It enables to accessing any data with support of electronic component. The description of the IoTs components and layers architecture is illustrated in Figure 1. In the IoTs system, the observation layers collect data from sensor, device, and another component that lived in the industry environments. The perceptions layers are accountable for collect real-times information for monitor and controlling purpose. Though, it is also exposed to numerous cyber-attacks that could have simple consequence on industry operation. Next, we present lists of potentials attack that can targeted these layers.

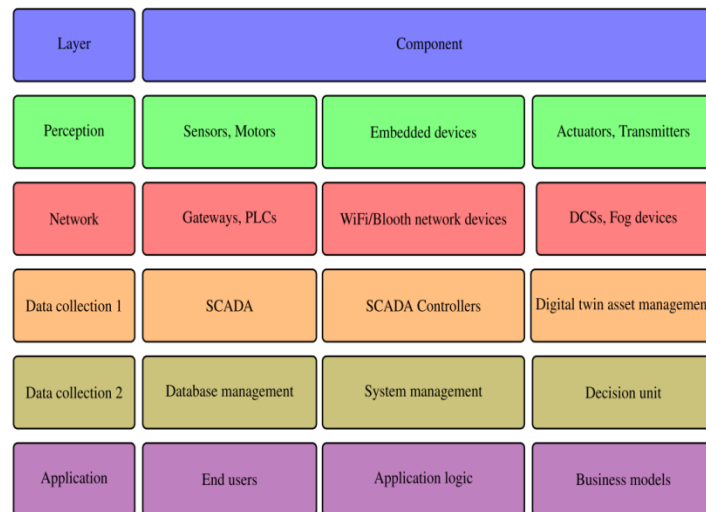

Figure 1: Component of the IoT layers architectures

The automated waginger systems is shown in Figure 2 illustrate the complete structure design of the systems proposed by [20]. This system includes sensors acquisition controlling networks,

which collect data about numerous environments, equipment management, which represent the agriculture equipment in the greenhouses, networks transmitters, which receive data from the greenhouses and send it to the cloud platforms, and application platforms, which detect and control the greenhouse systems

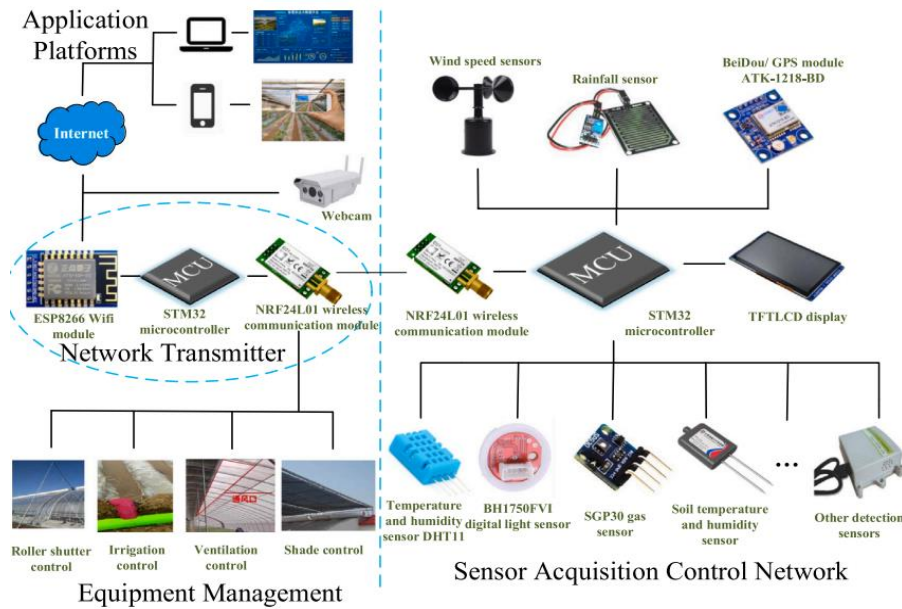

Figure 2: Automated Waters systems proposed by [20]

## 2. Material and Methods

Figure 3 shows proposed Simulink models to implements smart plants watering systems depend on IoT technology. In this model, the hardware includes Arduino Mega 2560, Arduino Mega ADK, and Arduino Due. The providing models are pre-configuring for Arduino Mega 2560 which is running by change the hardware boards parameters. The development of Simulink models was implemented under smart plants watering systems. The watering requirement for plants could be decide by the perfect soils moistures ranges require for implementation. When the soils moistures is not in the perfect ranges, then the plants is over water or not water enough. Through measure the soils moistures levels, we could decide if the plants need to be watering. In order to measures the soils moistures, we used soils moistures sensors. These sensors measure the



percentages of moistures presented in the soils. Additional main resources for growths of plants are the quantity of sun lights it received.

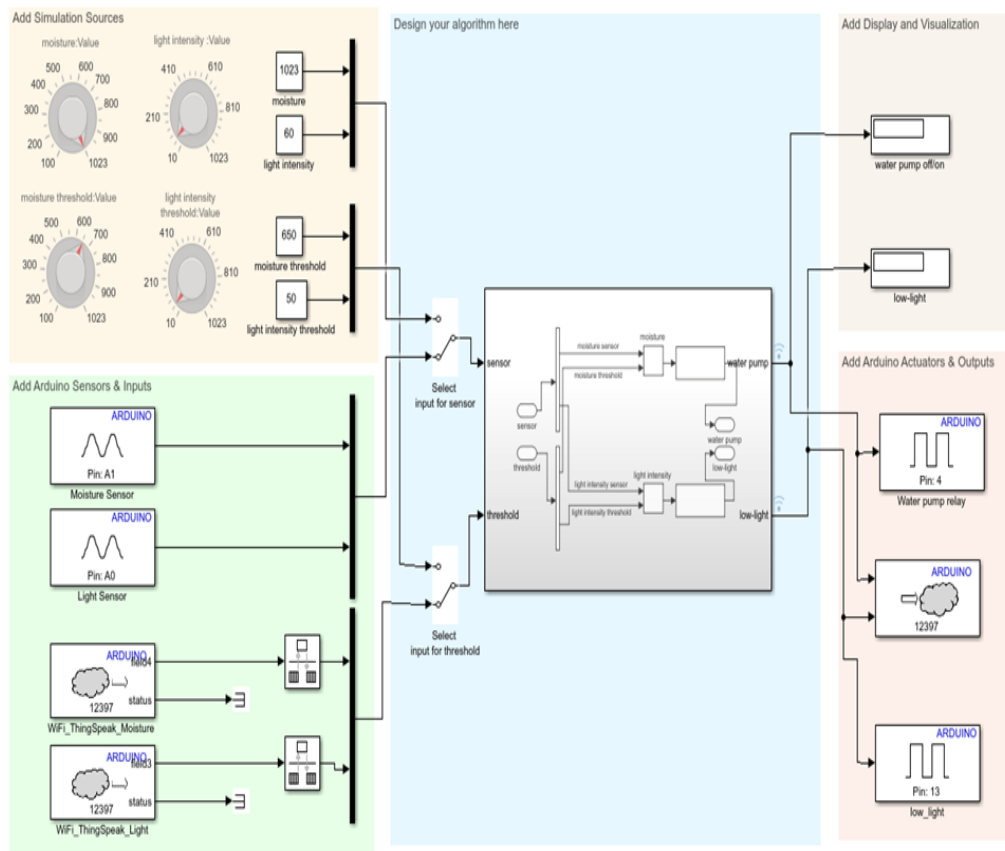

Figure 3: Proposed smart plant watering model using MATLAB

Through measures the intensities of lights reach the plants, we could determine if the requirement of plants is happened. The ambient lights intensities sensors could be usage to measures the quantity of lights incidents on the plants. The smart plants watering systems is contained of Arduino connects with a soils moistures sensors and a lights intensities sensor. Hence, depend on measures values of the moisture’s levels, the watering pumps connects to Arduino over relays shields is powers ON-OFF. The users are informed about a lower-lights conditions by use LEDs when the lights intensities measure is lesser than the thresholds levels set by the users. In order to offer additional adaptability to the users, we connects the Arduino to IoT applications analytics platforms which is enable to collects, stores, analyzer, visualizes, and acts on the information from sensor or actuator like Arduino. The initial elements of IoT activities are the



channels, which contain information field, locations field, and a situation fields. Afterward the creation of IoT channels, we can write information to the channels, processing and views the data with MATLABs codes, and reacts to the data with tweet and another alert. By connect the systems to IoT provide the subsequent capability:

1. Periodical sending the values of moistures and lights intensities to be store on IoT application which enabling the users to monitors the performances of the systems online from any parts of the worlds.
2. Thresholds values for soils moistures and lights intensities could be kept in IoT application to read the thresholds value from IoT and takes the required action. We could at several points of time changed the thresholds remote by set the values in IoT application to a diverse one. Then, this changed takes effects in the systems when Arduino read from IoT application throughout the subsequent cycles of operation. Figure 4 show the Configurations of suggested Models on Arduino Hardware.

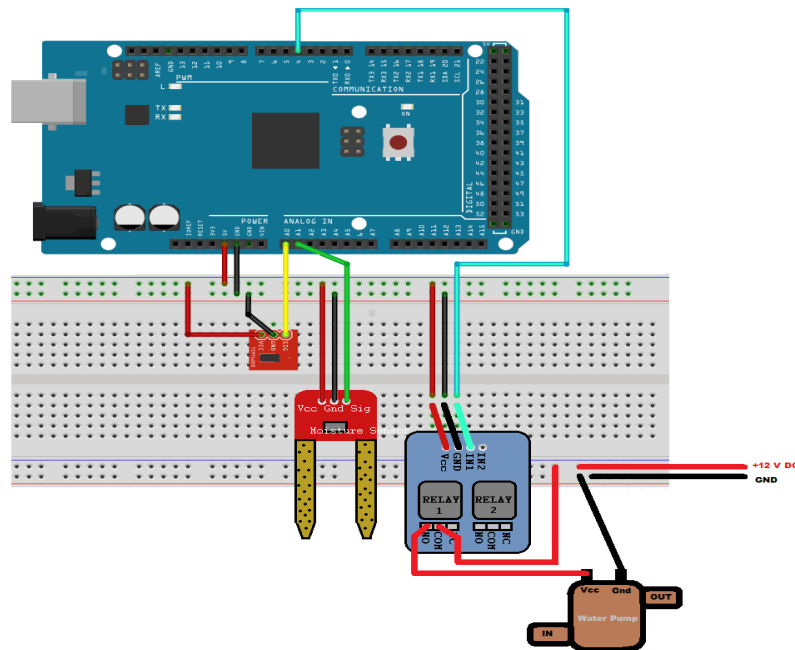

Figure 4: Configurations of suggested Models on Arduino Hardware



The suggested models were developed for simulations and utilization modes. In simulations modes, we use SIMULINK sources block to simulate the soils moistures sensors and ambient lights sensors. The outputs of the algorithms could be view by use a displaying or scopes blocks. Afterward the algorithms are running and verifying, we configured the models for Arduino hardware, builds and deploying the models on to the hardware.

### 3. Results and discussion

Figure 5 show the graphic presentation on the IoT application depend on the real-times detections. The reds dot in the graphs representation the intensities value repeatedly detects by the soils moistures sensors, processing in the microcontroller, send through the internet and recording by IoT application. A waters system connects to internets, and application was recording the soil moistures values in a real time manners. Two kinds of notification send to smartphones user include notifications is the messages if the devices are turn ON and performs the watering functions, and if the tools have finish perform the watering functions, the devices are turn OFF and systems sent the second notifications to user's smartphones over the application.

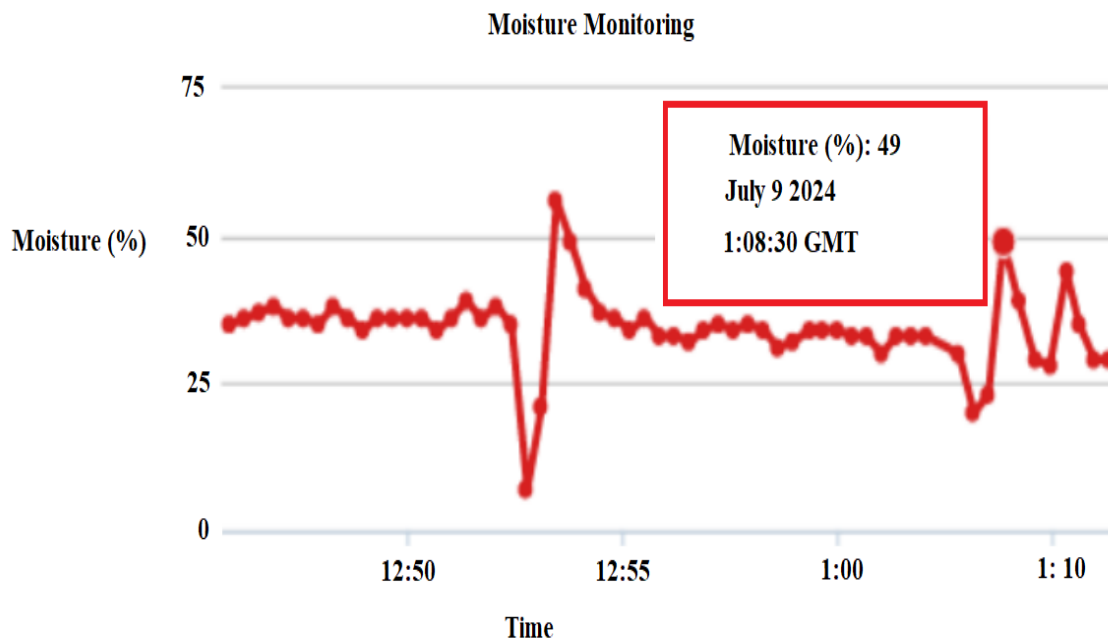

Figure 5: applications graphs monitoring the soils moistures



The test is achieved to find out whether the systems work correctly or not. Test also conducts by use the blacks' boxes test methods. The tests is carry out in the three part include the devices test to tests the functions of every component, test relate to the monitor of soils moistures over the application, and test about the notifications over application concerning the data about the devices if it's triggered or deactivate. The watering devices contain of the soils moistures sensors, D1 microcontrollers, relays, solenoids valves and watering pipes. The parameters for these tests are depending on detections result from the soils moistures sensors. In this paper, the reference of soils moistures is preferred and sets in the values among 40% - 45 %. if the sensors detect the soils moistures levels is among 40% to 45% then the soils are in a dry level. If the soils is dry, it mean the plant needs waters, thus the relays stated ON and trigger the solenoids valves to open the watering pipes to drains the waters to the plant. The testing result is illustrated Table. 1

Table 1: Functionalities testing of the watering device

No.	Soil moistures detection values	Wemos D1	Relays	Solenoid valve	Watering pipes	Test result
1	40% - 45%	ON	ON	Open	Enable drain water	Succeeded
2	More than 45%	ON	OFF	Closed	Disable drain water	succeeded

Figure 6 and Figure 7 shows the readings of temperatures and humidity values on hour's basis to check the values which mostly considered for numerous application examples greenhouse due to certain crop needs fewer values and some needs more. The comparative of the measured and actual temperature is illustrated as well.

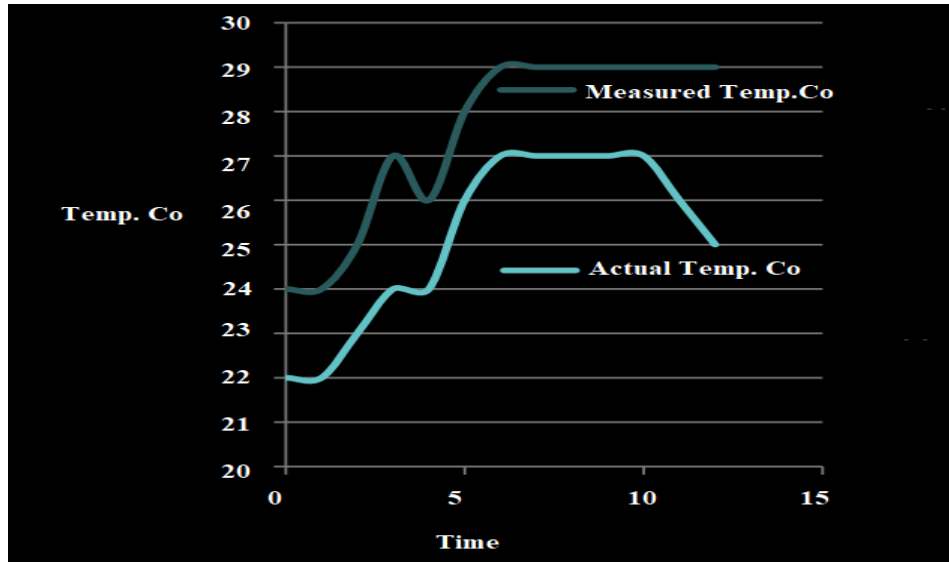

Figure 6: Temperature against Time

Table 2 shows the comparison of current studies with the suggested system. In the current system, authors consider old processors/controllers with smaller storage memories, lack of techniques usage, smaller sensors number and appropriate to fewer application. In the suggested system, new idea of IoT was considered, different sensor and representations of result in numerical and statement case.

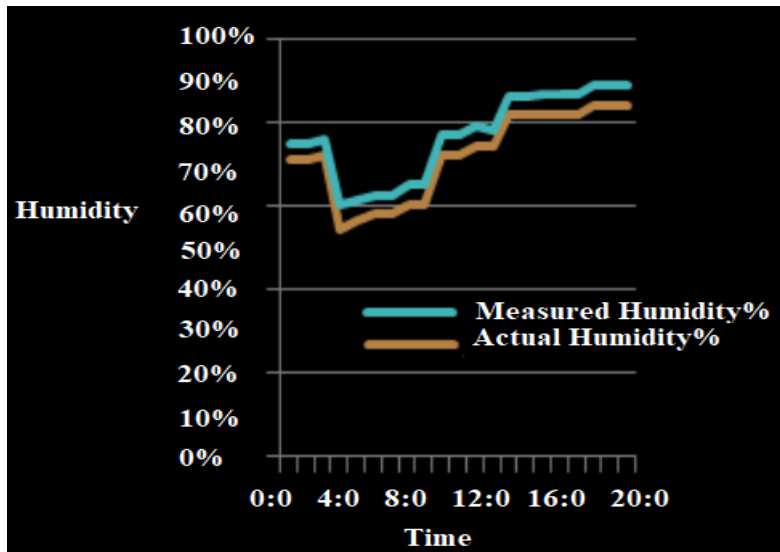

Figure 7: Humidity against Time

Table 2: Comparison between Current and Suggested Systems

Parameters	Current approaches	Suggested system
Technology	[17] IoT (2020)	IoT, MATLAB, SIMULINK
Web App, security	[11] less secure (2021)	More secure
Accessibility	[12] only user can access (2022)	All could be access
Processors	[15] RF24L01 (2022)	Arduino Mega 2560, Arduino Mega ADK
Sensors	[20] Moisture, Humidity, Temperature (2024)	Humidity, Temperature, wireless sensor network, soils moistures sensors, , relays, solenoids valves, IR

#### 4. Conclusions

The concepts of IoTs techniques use to connects device for collects data about the plant's requirements. Developments in agricultures for rural and urban area are rise in current decade with the advantage of digital technologies. The servers base web application is developed which is free anywhere and anytime if the systems has connected with internets. These systems will improve the resource in plants areas. The connection costs are bearable compare to larger instrument. Completely these suggested systems solve main issue of the agricultures fields. The automated water systems integrate with IoTs platform can achieve the function of watering the plants rendering to the purposes of the researches. In this paper, we set the primary values of the soil's moistures in ranges of 40% - 45%. The tests result of the IoT soils moistures monitor depend on the experiments scenarios, calculate the averages final values of soils moistures is 78,2%. This mean that, in one cycles of watering, the devices can perform the processing of moisturize the soils with averaged increase calculate 45,8%.



## References

- [1] R. Cheng , L. Zhang, S. Wu, S. Xu, S. Gao, H. Yu, Probability density machine: A new solution of class imbalance, Sci Programming-Neth 1(2021),7555587 <https://doi.org/10.1155/2021/7555587>
- [2] W. Zhao, L. Wang, S. Mirjalili, Artificial hummingbird algorithm: A new bio-inspired optimizer with its engineering applications, Comp Meth Appl Sci., 388 (2022) 114194. <https://doi.org/10.1016/j.cma.2021.114194>
- [3] J. Kaur, K. Kaur, Internet of Things: A Review on Technologies, Architecture, Challenges, Applications, and Future Trends, IJCNIS 9.4(2017),57. [10.5815/ijcnis.2017.04.07](https://doi.org/10.5815/ijcnis.2017.04.07)
- [4] Y. Achour, A. Ouammi, D. Zejli, Technological progresses in modern sustainable greenhouses cultivation as the path towards precision agriculture, Renew. Sust. Energ. Rev. 147 (2021), 111251. <https://doi.org/10.1016/j.rser.2021.111251>
- [5] S. Nath, M. Hossain, I. Chowdhury, S. Tasneem, M. Hasan, R. Chakma, Design and implementation of an IoT based greenhouse monitoring and controlling system, JCSTS, 3 (2021)01-06. [10.32996/jcsts.2021.3.1.1](https://doi.org/10.32996/jcsts.2021.3.1.1)
- [6] C. Maraveas, D. Loukatos, T. Bartzanas, K. Arvanitis, F. Uijterwaal, Smart and solar greenhouse covers: Recent developments and future perspectives, Front Energy Res. 9(2021)783587, [10.3389/fenrg.2021.783587](https://doi.org/10.3389/fenrg.2021.783587)
- [7] D. Boursianis, M. Papadopoulou, P. Diamantoulakis, A. Liopa-Tsakalidi, P. Barouchas, G. Salahas, K. Goudos, Internet of things (IoT) and agricultural unmanned aerial vehicles (UAVs) in smart farming: A comprehensive review. (IoT). 18 (2022)100187, <https://doi.org/10.1016/j.iot.2020.100187>
- [8] M. Ouafiq, R. Saadane, A. Chehri, Data management and integration of low power consumption embedded devices IoT for transforming smart agriculture into actionable knowledge, Agriculture,12(2022) 329, <https://doi.org/10.3390/agriculture12030329>



- [9] Z. Zhang, Research on intelligent measurement and control system for internet of things in greenhouse, *J. Phys.: Conf. Ser.*, 1486 022037 (2020)2, <https://doi.org/10.1088/1742-6596/1486/2/022037>
- [10] R. Rayhana, G. Xiao, Z. Liu, Internet of things empowered smart greenhouse farming. *IEEE J Radio Freq Identif* , 4(2020)195-211, [10.1109/JRFID.2020.2984391](https://doi.org/10.1109/JRFID.2020.2984391)
- [11] D. Gzar, A. Mahmood, M. Al-Adilee, Recent trends of smart agricultural systems based on internet of things technology: A survey, *Comput Electr Eng.*, 104 (2022) 108453, <https://doi.org/10.1016/j.compeleceng.2022.108453>
- [12] C. Zhang, Z. Liu. Application of big data and agricultural internet of things technologies in smart greenhouse environment control - A case study of Jinan Kobai Intelligent. *Ag. Eng. T.* 41 (2021), 21–26. <https://doi.org/10.1177/1550147719881610>
- [13] M. Farooq, M. Riaz, S. Helou, F. Khan, A. Abid, A. Alvi, Internet of things in greenhouse agriculture: A survey on enabling technologies, applications, and protocols, *IEEE*, 10 (2022) 53374–53397, <https://doi.org/10.1109/ACCESS.2022.3166634>
- [14] M. Dhanaraju, P. Chenniappan, K. Ramalingam, S. Pazhanivelan, and R. Kaliaperumal, Smart Farming: Internet of Things (IoT)-Based Sustainable Agriculture, *Agriculture*, 12(2022)1745, <https://doi.org/10.3390/agriculture12101745>
- [15] P. Tan, T. Gebremariam, S. Rahman, H. Xu, Design and implementation of soil moisture monitoring and irrigation system based on ARM and IoT. *Procedia Comput Sci.*, 208 (2022), 486–493, <https://doi.org/10.1016/j.procs.2022.10.067>
- [16] J. Hua, H. Wang, M. Kang, X. Wang, S. Guo, F. Chang, F. Wang. The design and implementation of a distributed agricultural service system for smallholder farmers in China, *Int J Agric Sustain*, 21(2023),2221108. <https://doi.org/10.1080/14735903.2023.2221108>
- [17] M. Ambrosin, M. Conti, R. Lazzaretti, M.M. Rabbani, S. Ranise, Collective remote attestation at the internet of things scale: State-of-the-art and future challenges, *IEEE*, 22(2020)2447-2461, <http://dx.doi.org/10.1109/COMST.2020.3008879>



- [18] N. Chamara , M. Islam , G. Bai , Y. Shi, Y. Ge, Ag-IoT for crop and environment monitoring: Past, present, and future, Agricultural Sys., 203 (2022)103497, <https://doi.org/10.1016/j.agry.2022.103497>
- [19] W. Jabbar, T. Subramaniam, E. Ong, M. Shu'Ib, W. Wu, M. de Oliveira, A. Lorawan-based IoT system implementation for long-range outdoor air quality monitoring. Internet of things (IoT), 19 (2022) 100540, <https://doi.org/10.1016/j.iot.2022.100540>
- [20] Y. Song, J. Bi, X. Wang, Design and implementation of intelligent monitoring system for agricultural environment in IoT, Elsevier-Internet of Things (IoT), 25 (2024) 101029 <https://doi.org/10.1016/j.iot.2023.101029>

## نظام مراقبة فعال لسقي النباتات بناءً على إنترنت الأشياء (IoT) باستخدام MATLAB

مسلم مجيد حميد الحمادي

جامعة البصرة/ كلية الفنون الجميلة / قسم وحدة الأرشفة

### المستخلص

تعرض هذه الورقة تطوير الأنظمة المدمجة لمراقبة النباتات وأنظمة الري المعتمدة على إنترنت الأشياء (IoT) باستخدام برنامج MATLAB. تم تقديم نموذج إنترنت الأشياء لتوصيل الجهاز عبر الإنترنت وتمكين المستخدم من الوصول إلى البيانات. يمكن لهذا النموذج تحقيق المراقبة الصحيحة للبيانات البيئية في المجالات الزراعية ومن ثم نقل بيانات مماثلة للمستخدم. يراقب النموذج معلومات متنوعة مثل درجات الحرارة والرطوبة وشدة الضوء. تُستخدم مستشعرات الأشعة تحت الحمراء لفحص أي أجسام خارجية تدخل إلى الحقول، وفي حالة اكتشاف المتطفلين، سيتم تشغيل صفارات الإنذار لمدة ثوانٍ أقل. يعمل المحرك في ظروف يدوية وأتوماتيكية تعتمد على أجهزة استشعار الرطوبة. يتم تبديل المحرك بشكل روتيني بين مرحلة التشغيل والإيقاف لعمليات المضخة. يتم ملاحظة النتيجة في تطبيقات الويب والشاشات. تتم معالجة محطة المياه عادةً يدويًا فيما يتعلق بكميات المياه التي يرغب فيها المصنع. في بحثنا، تم مناقشة النماذج الأولية ووظائف الأنظمة لمحطات الري على أساس مستويات الرطوبة. بالإضافة إلى ذلك، توفر هذه الورقة تطبيقًا أكثر أمانًا ويمكن للعديد من المستخدمين الوصول إليه مقارنة بالطرق الحالية

